

## Chapter 6: An analysis of Italian (Romance)

**6.1 Prenominal and postnominal adjectives in Italian (Romance).** For Italian (Romance) the order of Merge is not immediately visible due to the intervention of (various) movements, which in some cases are obligatory and in others optional.

It was noted above that indirect modification APs (with their interpretations) necessarily follow the N (plus any direct modification APs, if present). See, for example:

- |  | dir. mod. | indir. mod. |
|--|-----------|-------------|
| (1)a Maria intervistò ogni potenziale candidato possibile  |           |             |
| ‘Maria interviewed every potential candidate possible (that it was possible for her to interview)’ |           |             |
| b Maria intervistò ogni candidato potenziale possibile   |           |             |
| ‘Maria interviewed every candidate potential possible (that it was possible for her to interview)’ |           |             |
| c *Maria intervistò ogni possibile potenziale candidato/candidato potenziale                       |           |             |
| ‘Maria interviewed every possible (that it was possible for her to interview) potential candidate’ |           |             |

This implies that the entire constituent made up of the NP and its direct modification adjectives (the [FP<sub>2</sub>] of (2)) (obligatorily) raises above the indirect modification AP found in the reduced RC (like, I would claim, it obligatorily raises above a full relative clause, merged prenominally).

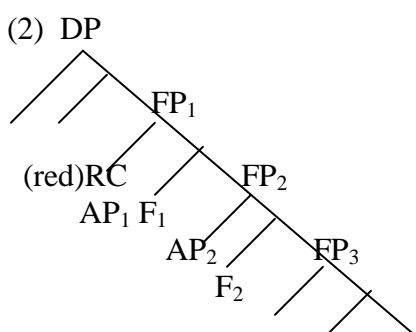

AP<sub>3</sub>  
F<sub>3</sub>      NP

This is rendered plausible by the fact that Romance (as opposed to Germanic) similarly allows no reduced relative clauses to precede the N. Compare (3) with (4):

(3)a \*le recentemente arrivate lettere      (Italian)

the recently arrived letters

b \*les récemment arrivées lettres      (French)

the recently arrived letters

c \*la escrita carta/\*el roto libro (Spanish – Luján 1980,49; Demonte 1999b,54)

the broken book/the written paper

d \*deja sositele cărți/\*niște căzute frunze (Romanian – Carmen Dobrovie-Sorin, p.c.; Dumitrescu)

already arrived.the letters/some fallen leaves      and Saltarelli 1998,187, respectively)

‘the already arrived letters/the fallen leaves’

(4)a the inadvertently killed passangers (English - Barkai 1972)

b die kürzlich angekommenen Briefe (German – Walter Schweikert, p.c.)

the recently arrived letters

c en mördad man      (Swedish – Delsing 1993a,110)

a murdered man

In other words, in Romance, all kinds of relative clauses, whether full or reduced, seem to have to end up after the NP and its direct modifiers.<sup>1</sup> The fact that most direct modification APs (with their interpretations) also follow the noun implies that the NP also raises above (most) direct modification APs inside the constituent that raises above reduced relative clauses (as shown by the arrow inside the box in (5)):

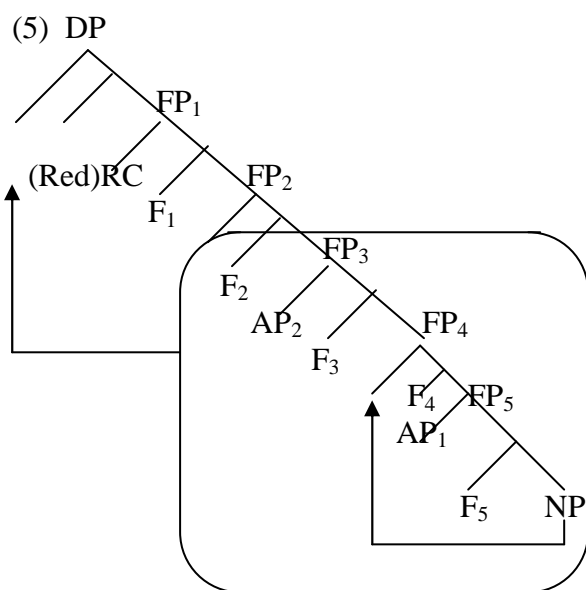

For the latter type of raising one has to distinguish the case where the raising of the NP (or of a bigger phrase containing the NP) around direct modification adjectives is obligatory from the cases in which it is optional or impossible. In Italian, for example, the NP obligatorily raises above classificatory adjectives (cf. (6)-(7)), and adjectives of provenance/nationality ((8)-(9)),<sup>2</sup> but appears to raise above higher adjectives (of colour, shape, size, value, etc.) only optionally (cf. (10)-(11)).<sup>3</sup>

(6)a \*Gianni è un **elettronico** ingegnere

b Gianni è un ingegnere **elettronico**

‘Gianni is an electrical engineer’

(7)a \*Il **centrale** comitato

b Il comitato **centrale**

‘the central committee’

(8)a \*un **cinese** vaso

b un vaso **cinese**

‘a Chinese vase’

(9)a \*la **romana** invasione della Tracia

b l’invasione **romana** della Tracia

‘the Roman invasion of Thrace’

(10)a Le **verdi** colline della Toscana

b Le colline **verdi** della Toscana

‘The green hills of Tuscany’

(11)a il **tondo** ovale del suo viso

b l’ovale **tondo** del suo viso

‘the round oval of her face’

(12)a l’**enorme** sagoma della cupola

b la sagoma **enorme** della cupola

‘the enormous outline of the cupola’

(13)a il **prezioso** contributo di Gianni

b il contributo **prezioso** di Gianni

‘Gianni’s precious contribution’

The question why NP raising across classificatory and provenance/nationality APs is obligatory, while it is optional with higher classes of adjectives (except some, across which it is impossible: *mero* ‘mere’, *povero* ‘pitiful’, *vecchio* ‘of long-standing’, *futuro* ‘future’, etc.) remains to be

understood. The national Romance languages (Italian, French, Catalan, Spanish, Portuguese, Romanian), despite certain limited differences,<sup>4</sup> are remarkably similar in this respect. Greater variation is found when one takes dialects, or older stages, of these languages into consideration. For example, in Walloon (Bernstein 1991,105 and fn.5;1993a), the NP does not cross any AP except for nationality ones<sup>5</sup>, while in Old Italian the NP could fail to cross nationality adjectives (Giorgi to appear, sections 4.1.6-7; Giusti to appear, sections 2.3-4; Thiella 2008, chapter 4), as well as the lower classificatory ones (cf. *le sette liberali arti* ‘the seven liberal arts’, from Dante’s *Novellino*, cited in Benincà and Cinque (2008, section 3.2.1)). In Sardinian (Jones 1993, section 2.1.4), and in some Central Italian dialects (Saltarelli 1999), on the other hand, the NP raises obligatorily across all APs except a handful.

Since the order of postnominal direct modification APs in Italian (Romance) is the mirror image of the English (Germanic) prenominal order (compare (14)a-c, and especially (17)-(18) below, with their English translations), the raising must be (pace Dehé and Samek-Lodovici 2007, sections 4.2-3) of the “roll-up” kind; i.e., it must involve at each step pied piping of the *whose-picture* type (Cinque 2005), as sketched in (15) below:

(14)a un cane nero enorme

a dog black enormous

‘an enormous black dog’

b un tavolo cinese rotondo

a table Chinese round

‘a round Chinese table’

c una piazza grande bellissima

a square big beautiful

‘a beautiful big square’

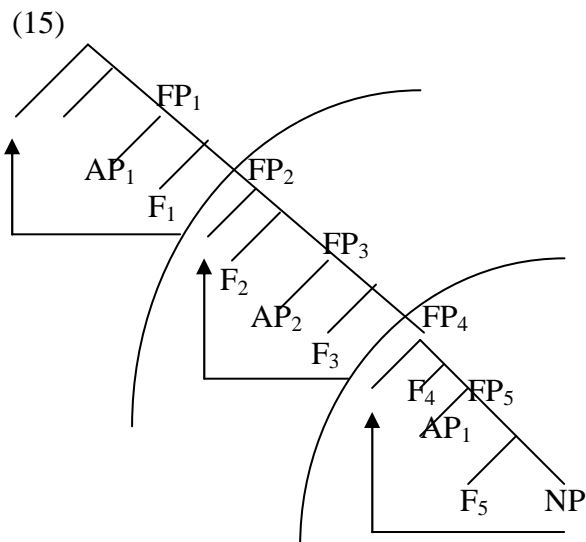

Of course, as in the English case of (*I want*) *a brówn big dog* seen above, in Italian too the opposite order is possible (though more special) alongside the unmarked order seen in (14):

- (16)a un cane enorme néro  
 b un tavolo rotondo cinése  
 c una piazza bellissima gránde

As in the English case, I take the unmarked order of (14) to reveal the (derived) rigid order of direct modification adjectives in Italian (which is the mirror image of the English one), and I interpret the more special order of (16) as the result of merging the rightmost adjective higher up as a reduced relative clause (which eventually ends up postnominally after the direct modification adjective).<sup>6</sup>

The reversal of the order seen in (16) should be impossible whenever the adjective closer to the N is one of direct modification only, as this cannot access the relative clause source. As with the English cases seen above, this expectation is confirmed:<sup>7</sup>

- (17)a la ripresa economica americana  
 the recovery economic American

b \*la ripresa americana economica  
the recovery American economic  
'the American economic recovery'

(18)a l'unico cliente abituale possibile  
the only customer regular possible  
b \*l'unico cliente possibile abituale  
the only customer possible regular  
'the only possible regular customer'

A traditional observation is that certain adjectives can never be postnominal. In the present system, this can be taken to mean that such adjectives cannot be crossed over by the NP (or a larger phrase containing it). In some cases this may depend on the fact that the adjectives are merged in positions which are higher than the positions to which the NP (or the phrase containing it) may raise.<sup>8</sup> It is thus interesting that adjectives which, judging from the position in the clause of the corresponding adverbs (Cinque 1999), are possibly among the highest (*presunto*, *sedicente* 'alleged', *ex* 'former', *futuro* 'future, next in turn'), are exclusively prenominal:<sup>9</sup>

(19)a (Si è fatto vivo) un sedicente erede  
(has appeared) an alleged heir  
An alleged heir appeared  
b (Si è fatto vivo) \*un erede sedicente  
(has appeared) a heir alleged  
An alleged heir appeared

(20)a l'ex primo ministro (è stato arrestato)

the former prime minister (has been arrested)

b \*il primo ministro ex (è stato arrestato)

the prime minister former (has been arrested)

The exclusively prenominal occurrence of an adjective (under a certain interpretation) may also be at the basis of certain meaning contrasts. Cases like (21)-(22), where the adjective appears to change meaning according to whether it occurs prenominally or postnominally, can be seen to depend on the fact that the adjective occupies two distinct positions, one of which (the prenominal one) is high in the direct modification space and is not crossed over by the NP (see (23)), while the other (the postnominal one) is either low in the direct modification space and is crossed over by the NP, or is an indirect modification adjective, merged higher and crossed over by the constituent comprising the NP plus any direct modification adjective. This can be seen more clearly when both positions are filled (as in *le numerose famiglie numerose che si erano presentate* ‘the many numerous families that had come..’). See (24):

(21) *le numerose famiglie che si erano presentate*

the numerous (=many) families that had come

(22) *le famiglie numerose che si erano presentate*

the numerous (=with many members) families that had come

(23)a *le [numerose (=many) [...[...[famiglie ]]]]*..→ raising of NP

b *le [numerose (=many) [famiglie [...[ t ]]]]*

(24)a *le [numerose (=many) [...[numerose(=with many members) [famiglie ]]]]*..→ raising of NP

b *le [numerose (=many) [famiglie [numerose (=with many members) [ t ]]]]*



There are also more subtle minimal pairs, like (25), which involve the subject-oriented and manner readings of adjectives such as *brutale* ‘brutal’, discussed in Cinque (1994, section 2):

(25)a la loro brutale aggressione all’Albania

the their brutal aggression to Albania

b la loro aggressione brutale all’Albania

the their aggression brutal to Albania

‘their brutal aggression against Albania’

The adjective in prenominal position has a subject-oriented interpretation while the adjective in postnominal position has a manner interpretation. This suggests that subject-oriented adjectives are higher than manner adjectives (Cinque 1994, section 2), much like the corresponding adverbs in the clause (Jackendoff 1972, chapter 3; Cinque 1999, 19f), and fail to be crossed over by the NP, which instead necessarily crosses over the lower manner adjective position.

A high location of the adjective cannot however explain all cases of exclusively prenominal adjectives. There are exclusively prenominal adjectives that apparently follow in linear order (are lower than) direct modification adjectives that can be postnominal as well as prenominal. See the combination of the exclusively prenominal *perfetto* (under the relevant reading of ‘applying perfectly’)<sup>10</sup> with the pre- and postnominal adjective *possibile* ‘possible’:

(26)a un possibile perfetto sconosciuto

a possible perfect stranger

b \*un perfetto possibile sconosciuto

a perfect possible stranger

c \*un possibile sconosciuto perfetto

a possible stranger perfect

d un perfetto sconosciuto possibile

a perfect stranger possible

‘a possible perfect stranger’

This suggests that reasons other than height of merger may be at the basis of the exclusively prenominal character of certain classes of adjectives. These reasons may be in part different in different Romance languages. Although, as noted, they are in essence identical in the class of adjectives that are necessarily postnominal, necessarily prenominal and either pre- or postnominal (see Bernstein 1993a on French and Spanish, Cornilescu 2003b, Cinque 2004 on Romanian, Gonzaga 2004 on Portuguese, and the present Chapter on Italian), there are nonetheless (limited) differences.

So, for example, *bon/buono* ‘good’ in its “approximate” use is only prenominal in French (*il faudra une bonne heure*/\**heure bonne* – cf. Bouchard 2002,91), but can be postnominal in Italian (*per arrivare ci vorrà un’ora buona*/(?)*una buona ora* ‘to arrive a good hour will be necessary’).

As noted by Abeillé and Godard (2000,340), some exclusively prenominal adjectives in French can also appear postnominally if coordinated with another adjective. So, for example, *vrais* ‘real’ and *faux* ‘fake’ cannot by themselves be postnominal (*Des vrais coupables*/\**Des coupables vrais* ‘real culprits’; *Des faux coupables*/\**Des coupables faux* ‘fake culprits’). But they can, if coordinated together (*Des vrais ou faux coupables*/*Des coupables vrais ou faux* ‘real or fake culprits’). Similar facts hold in Italian (Compare *una vera menzogna*/\**una menzogna vera* ‘a true lie’ with *una menzogna vera e propria* ‘a lie true and real’, *una pura coincidenza*/\**una coincidenza pura*, *una semplice coincidenza*/\**una coincidenza semplice* with *una coincidenza pura e semplice* ‘a coincidence pure and simple’.<sup>11</sup>

I tentatively interpret this fact as suggesting that when coordinated they count more easily as emphasized (“heavy”), and can thus access the Spec of a lower FocusP, ending up in postnominal

position as a consequence of the subsequent movement of the remnant (with their pre- or post-complement position depending on the relative height of the P with respect to FocusP – for which see the discussion in the next section).<sup>12</sup>

Italian (Romance) prenominal adjectives (whether obligatorily prenominal or not) are, as noted, only direct modifiers, with certain associated interpretive properties (individual-level, nonrestrictive, nonintersective, etc. readings). As such, they are, qua direct modifiers, also non-predicative. This means that, should one of these adjectives also appear in predicate position, it ought to be ambiguous between a direct modification usage and a usage as a predicative, indirect modification, adjective (with the other set of associated interpretive properties: restrictive, intersective, etc. readings). A case in point appears to be the adjective *falso* ‘false, fake’. This adjective can appear prenominally, thus qualifying as a direct modifier, with the associated nonrestrictive, nonintersective, etc. readings ((27)); yet it can also be found in predicate position ((28)a), and postnominally ((28)b), with all the properties (restrictive, intersective, etc.) of indirect modification adjectives:

(27) Questo è un falso problema

This is a false problem

(28)a Questa notizia è falsa

This piece of news is false

b Questa è una notizia falsa

This is a false piece of news

As one should expect, the meaning of *falso* in (27) is not the same as the meaning of *falso* in (28). In (27), it is a “privative” adjective (Partee 2003a,b); one which denies that the N is an appropriate description for a certain situation (the interpretation being that ‘it is not a (real) problem’). In (28),

instead, the adjective does not deny the appropriateness of the noun as a description of the facts. The piece of news may well be real news, though not one corresponding to the truth. This is particularly clear in the following minimal pair:

(29)a *Le false banconote con cui giocano..*

‘The fake bills with which they play..’

b *Le banconote false con cui giocano*

‘The fake bills with which they play..’

In the first case one refers to something that is not a real bill (e.g. Monopoly money); in the second case to something, possibly indistinguishable from real money, which has been counterfeited.<sup>13</sup>

The fact that certain languages only have the direct modification, “privative”, reading of ‘false, fake’ (as is apparently the case of Mandarin Chinese; see note 7 of the Appendix) indirectly confirms the conclusion, drawn here on word order and interpretive grounds, that two separate uses of *falso* (a direct modification and an indirect modification one) should be posited. In this respect, English seems to pattern with Italian, even if the distinction between the two usages of ‘false/fake’ is less evident than in Italian (due to the fact that in English both are prenominal), and is generally not recognized in the semantic literature (Kamp 1975, Kamp and Partee 1995, and Partee 2003a,b).

**6.2 The position of PP complements and adjuncts vis a vis adjectives in Italian (Romance).** An apparent problem for an analysis which postulates movement of the NP (or of a larger phrase containing it) rather than of just the head N is the fact that PP complements of the noun, rather than being dragged along by the NP in its raising, appear to be stranded at the end of the DP. Under the traditional analysis which first merges Ps with their complement, and then the resultant PP with the ‘head’ N, this is indeed problematic. However, the apparent stranding of complement and adjunct

PPs at the end of the DP is exactly what is to be expected under Kayne's (2000,2001,2002) analysis of prepositions. According to that analysis, prepositions are heads merged high in the extended projection of the NP (or outside of the DP altogether). They attract their "complements", and force (in VO languages) the entire remnant to raise to their left, which makes them final in the DP. More accurately, their DP-final position is achieved as sketched in (30):<sup>14</sup>

- (30)a [those [two [nice [books [syntax]]]]] → (merge of K(ase) and attraction of the DP to its Spec)  
 b [[syntax] K [those [two [nice [books t]]]]] → (merge of P (*on*) and attraction of the remnant)  
 c [[those [two [nice [books t]]]] on [[syntax] K t]

In Romance, while postnominal adjectives found between the head N and its (PP) complement(s) can either be direct modification adjectives or indirect modification adjectives, adjectives following a (PP) complement of the N are necessarily indirect modification adjectives.

This is clearly exemplified in Italian by the different interpretations associated with the different positions occupied by the adjective *industrioso* in (31)a-c:<sup>15</sup>

(31)a Gli **industrioso** greci di Megara di sicuro saranno premiati

b I greci **industrioso** di Megara di sicuro saranno premiati

c I greci di Megara **industriósi** di sicuro saranno premiati

'The industrious Greeks of Megara will certainly receive a prize'

(31)a has a nonrestrictive interpretation only ('all the Greeks of Megara, who are industrious, will receive a prize'). This is expected, as we saw, from the prenominal status of the adjective. (31)b is ambiguous. It can either have the nonrestrictive interpretation of (31)a, or a restrictive interpretation ('among the Greeks of Megara, only those who are industrious will receive a prize'). This follows from the two possible sources of the adjective. It can either be merged as a direct modifier, and be

crossed over by the NP (in which case it will retain all and only the readings of direct modification adjectives; in the case at hand, the nonrestrictive one), or it can be merged higher up, as the predicate of a reduced relative clause, and be crossed over by the NP plus its direct modifiers, if any (in which case it will have only the restrictive reading). (31)c is unambiguous. It only has the restrictive reading of indirect modification adjectives.

Under the analysis sketched above, after Kayne's, the necessary indirect modification character of adjectives following a PP complement may be seen to follow from the fact that both complements and relative clauses (but, we would add, no direct modification adjectives), may undergo movement to a higher position followed by merger of a P or of an (overt or covert) complementizer which subsequently forces movement of the entire remnant to their left, making them DP-final.

Depending on whether C or P is merged higher than the other, the (reduced) relative clause or the PP complement/adjunct will be absolutely final and the other next to final (see the two alternative derivations in (32)-(33)):<sup>16</sup>

(32)a [gli [industriosi [greco [Megara]]]] → (merge of K(ase) and attraction of the DP to its Spec)

b [[Megara] K [gli [industriosi [greco t]]]] → (merge of P (*di*) and attraction of the remnant)

c [[gli [industriosi [greco t]]] di [[Megara] K t]] → (merge of C and attraction of *industriosi*)

d [industriosi C [[i [t [greco t]]]] di [[Megara] K t]] (merge of C and attraction of the remnant)

e [[[i [t [greco t]]]] di [[Megara] K t] [industriosi C t]] → **i greco di Megara industriosi**

(33)a [gli [industriosi [greco [Megara]]]] → (merge of C and attraction of *industriosi*)

b [industriosi C [[i [t [greco Megara]]]]] → (merge of C and attraction of the remnant)

c [[[i [t [greco [Megara]]]] [industriosi C t]]] (merge of K and attraction of the DP to its Spec)

d [[Megara] K [[[i [t [greco]]] [industriosi C t]]] → (merge of P and attraction of the remnant)

e [[[[[i [t [greco]]] [industriosi C t]]] di [[Megara] K t]]] → **i greco industriosi di Megara**

In other words, the ordinary derivation is that shown in (33), where merger of a (covert) C precedes merger of P. In (32) the C which is merged later than P is actually a Focus head.

If direct modification adjectives (unlike adjectives merged as predicates of a reduced relative clause) cannot be attracted to a (covert) C higher than the position where Ps are merged (in fact, cannot be attracted *tout court*), they will necessarily be to the left of the PP. Only indirect modification APs will thus be able to follow a PP complement or adjunct of the head. Given that when they follow the PP, as noted, they must be heavily stressed, modified, coordinated, or followed by a complement or adjunct, it is reasonable to assume that they actually move to the Spec of a FocusP.<sup>17</sup>

The only classes of modifiers that can appear after a PP without being specially stressed are those that are allowed postnominally in English (and after *celui* in French, for which see section 6.4).

This suggests that they count as ‘heavy’, perhaps for the reasons discussed in Chapter 5, section 5.3, in connection with English; i.e., because they involve more, non pronounced, structure (as (37) shows, they can follow the noun’s complement even without being heavily stressed, modified, coordinated, or followed by a complement or adjunct):

*full relative clause:*

(34) I sostenitori di Gianni che conosciamo  
‘the supporters of Gianni that we know’

*reduced relative clause:*

(35) I sostenitori di Gianni convocati recentemente  
‘the supporters of Gianni summoned recently’

*PP modifiers:*

(36) I sostenitori di Gianni di convinzioni liberali

‘the supporters of G. of liberal convictions’

*special classes of adjectives:*

(37) i sostenitori di Gianni presenti/disponibili/pronti/...

‘the supporters of G. present/available/ready/...’

In other words, bare indirect modification adjectives under normal conditions can undergo a derivation like (38), but not one like (39):

(38)a [YP fedeli [NP sostenitori Gianni]                      merge of X° and attraction of NP to its Spec,  
followed by merger of D →

b [i [[sostenitori Gianni] X° [YP fedeli [NP]]]] merge of K° and attraction of *Gianni* to its Spec →

c [Gianni K° [i [[sostenitori t] X° [YP fedeli [NP]]]] merge of *di* and attraction of the remnant →

d [i [[sostenitori t] X° [YP fedeli [NP]]]] di [Gianni K° [t]]

‘(lit.) the supporters faithful of G.’

(39) [unavailable]

a [YP fedeli [NP sostenitori Gianni]                      merge of K° and attraction of *Gianni* to its Spec →

b Gianni K° [YP fedeli [NP sostenitori t]]              merge of *di* and attraction of the remnant →

c [YP fedeli [NP sostenitori t]] di Gianni K° t      merge of C<sub>1</sub>° and attraction of *fedeli* →

d fedeli C<sub>1</sub>° [YP t [NP sostenitori t]] di Gianni K° t      merge of C<sub>2</sub>° and attraction of the remnant →

e (i) [YP t [NP sostenitori t]] di Gianni K° t C<sub>2</sub>° fedeli C<sub>1</sub>° t

‘(lit.) the supporters of G. faithful’



With ‘heavy’ indirect modification adjectives both derivations are instead possible (cf. *i sostenitori fedeli al loro leader di Gianni* ‘(lit.) the supporters faithful to their leader of G.’, and *i sostenitori di Gianni fedeli al loro leader* ‘(lit.) the supporters of G. faithful to their leader’).

The fact that subject PPs generally precede oblique PPs (the direct order) in Romance, despite the adjectives showing an inverse order, is taken by Giurgea (to appear, section 2.0) to be a problem for a DP-internal phrasal movement analysis, and for a cartographic approach more generally. But under Kayne’s analysis of prepositional phrases adopted here this conclusion is not necessary. In particular the order subject PP > oblique PPs is reminiscent of superiority, and can be treated along similar lines (cf. Krapova and Cinque 2008, section 7).

**6.3 The position of demonstrative reinforcers vis a vis adjectives in Italian (Romance).** Just as complement (and adjunct) PPs in Italian constitute a divide between direct modification adjectives (only possible to their left) and indirect modification adjectives (possible both to their left, and to their right if focused), so do demonstrative reinforcers (like the *qui* of (40)), studied for Romance in Brugè (1996, 2002), Brugè and Giusti (1996), Bernstein (1997), and Ihsane (2003) (also see Leu 2007a, 2008):

(40) questi (tre) (bei) libri **qui**

These three nice books here (dem. reinf.)

‘these here three nice books’

As shown by the examples in (41), which contain direct modification adjectives, these can only occur to the left of the reinforcer:<sup>18</sup>

(41)a Questo figlio <unico> qui <\*unico> se l’è cavata benissimo

This child <only> here <only> managed very well

‘This only child managed very well’

b Quel salario <medio> lì <\*medio> non farebbe gola a nessuno

that salary <average> there <average> would tempt no one

‘That average salary would tempt no one’

c Quel sistema <immunitario> lì <\*immunitario> è simile al nostro

that system <immune> there <immune> is similar to ours

‘That immune system is similar to ours’

d Quel fisico <atomico> lì <\*atomico> era un genio

that physicist <atomic> there <atomic> was a genius

‘That atomic physicist was a genius’

Adjectives which are not necessarily direct modifiers, like those in (42), can instead appear either before or after the demonstrative reinforcer:

(42)a Questi cuori <infranti> qui <infranti> mi fanno pena

these hearts <broken> here <broken> make me feel sorry

‘These broken hearts make me feel sorry’

b Quella penna <rossa> lì <rossa> non è nostra

that pen <red> there <red> is not ours

‘That red pen is not ours’

c Questi piatti <pronti> qui <pronti> vanno serviti subito

These dishes <ready> here <ready> have to be served immediately

‘The dishes ready have to be served immediately’

Modifying in part Brugè's (2002) and Bernstein's (1997) analyses, I will assume that the demonstrative and the demonstrative reinforcer is a constituent merged immediately below the determiner; the XP of (43) (but see Leu 2007a,2008 for a more articulated analysis).<sup>19</sup>

(43) [Det [[<sub>XP</sub> *questi qui*] [*tre* [*bei* [*libri*]]]]]

Det these here three nice books

To derive the order in (40), one may assume that the demonstrative first raises to Spec,Det (cf. Leu 2007a,2008);<sup>20</sup> after which there is attraction of *qui* to the Spec of a higher head, followed by merger of a head which attracts the entire remnant (the latter head actually appears to be spelled out in Spanish, as *de* – see (45):

(44)a [*questi* [Det [[ *t qui*] [*tre* [*bei* [*libri*]]]]] → merger of a head and attraction of *qui*

b [*t qui* X [*questi* [Det [[ *t t*] [*tre* [*bei* [*libri*]]]]] → merger of a head and attraction of the remnant

c [*questi* [Det [[ *t t*] [*tre* [*bei* [*libri*]]]]] Y [*t qui* X *t*]

(45) *este* (...) *libro de aqui*<sup>21</sup>

this book of here

'this book'

As with the adjectives following a complement or adjunct PP, I will assume that the adjectives following a demonstrative reinforcer have accessed the Spec of a focus head higher than the position targeted by the demonstrative reinforcer (which excludes, as noted, direct modification adjectives).

**6.4 Adjectives after *celui* in French.** The account proposed for those adjectives that follow a PP and the demonstrative reinforcer in Romance may prompt an account of the parallel fact that no indirect modification adjective (nor direct modification adjective, for that matter) can be found after *celui* in French (see (46)), except for those classes that can appear postnominally in English and after a complement or a demonstrative reinforcer in Italian. See (47)-(51) (cf. Kayne 1994; Sleeman and Verheugd 1998a,b; Bouchard 2002,172ff; and references cited there).

(46) \**celui* jaune (Kayne 1994,100)

*full relative clause:*

(47) Le livre que Ida m'a donné ne m'a pas plu, mais celui que Paul m'a donné m'a beaucoup plu  
the book that I. gave to me didn't appeal to me, but the one that P. gave to me appealed to me a lot

*reduced relative clause:*

(48)a *celui* envoyé à Jean

the one sent to J.

b *celui* à faire

the one to do

*PP modifiers:*

(49) *celui* de Marie n'est pas beau, mais *celui* de Pierre est beau

the one by M. is not nice, but the one by P. is nice

*adjectives followed by a complement (or adjunct):*

(50) *celui* fier de son fils regardait Paul

the one proud of his son looked at Paul

*special classes of adjectives:* (Bouchard 2002,174)

(51)a ceux présents auront droit à un rabais

those present will have the right to a rebate

b ceux coupables/responsables seront punis

those guilty/responsible will be punished

c ceux prêts doivent être envoyés immédiatement

those ready must be sent immediately

If *celui* is high in DP (perhaps in Spec, DP - Kayne 1994,101), and there is an unpronounced C/P merged higher, then only those indirect modifiers that can be attracted to a focus head higher than C/P (crucially, neither direct modification adjectives nor bare indirect modification adjectives) will be found to cooccur with *celui*. Only focused indirect modification APs or APs with a larger (overt or covert) structure will be able to.

---

<sup>1</sup> See note 13 of the previous chapter. This Germanic/Romance contrast can be construed as an additional piece of evidence that the prenominal position in English cannot be taken as a diagnostic for adjectivehood, as it can also host reduced relative clauses (cf. the discussion in section 5.4 of the previous chapter).

Certain present and past participle can apparently occur before the noun in Italian (Romance) (*la restante somma* ‘the remaining sum’; *le agognate vacanze* ‘the craved for holidays’). There is, however, evidence that such prenominal forms are categorially adjectives (derived from participles). For example, a clitic, which can be found enclitic to a participle, but not to an adjective (as originally noted by Luigi Rizzi), cannot be enclitic to these forms when they are prenominal (\**Questa è la restantemi somma* ‘This is the remaining-to-me sum’), if not in very formal styles of Italian (see below), though it can when they are postnominal (*Questa è la somma restantemi* ‘This is the sum remaining-to-me’). Apparent past participles like *agognate* can bear the adjectival suffix *-issimo* of absolute degree (*le agognatissime vacanze* ‘the extremely craved for holidays’), and can be made superlative (*le più agognate vacanze* ‘the most craved for holidays’), options open to adjectives but not to verbal participles. It is only in very formal styles, apparently, that reduced relative clauses may precede the noun in Romance (cf. Giorgi 1988,307f). See, for example, *il*

---

*da poco restaurato museo atestino* ‘the recently renovated museum of Este’ (adapted from F.Sartori *Dall’Italia all’Italia*.Vol.II. Padova, Editoriale Programma, p.281), with the adverb *da poco* favouring the participial reading. In such cases, quite expectedly, the adjectival suffix *-issimo* is impossible. Compare the otherwise acceptable *il restauratissimo museo atestino* ‘the much renovated museum of Este’ (where, due to the absence of the adverb *da poco*, *restaurato* can be a (deverbal) adjective) with *\*il da poco restauratissimo museo atestino* ‘the recently much renovated museum of Este’.

Also see Cornilescu (2006, section 4.1) on the comparable possibility of prenominal stative participles in Romanian.

<sup>2</sup> The adjectives of these two classes (which actually comprise further subclasses) are also called “pseudo-adjectives” (Bartning 1980), “relational” (Giorgi and Longobardi 1991), or “associative” (Giegerich 2005). Those in (9) have also been called “thematic” (Cinque 1994, and references cited there), “ethnic” (Alexiadou and Wilder 1998), and “group” adjectives (Oersnes and Markantonatou 2002, Van de Velde 2006). On this class of adjectives, also see Fábregas (2007).

<sup>3</sup> This is of course true for the direct modification reading. For example, the prenominal position of the colour adjective in (10)a (this position is unavailable with invariant colour adjectives like *rosa* ‘pink’, *blu* ‘blue’, etc. – Zamparelli 1993,156) only has the individual-level, nonrestrictive, nonintersective, etc., readings (hence, its interpretation that all Tuscan hills are characteristically green). This reading (unexpectedly for Bouchard 1998,2002 and Alexiadou 2001, 2003) is preserved in postnominal position, though of course the stage-level, restrictive, intersective, etc., readings also become available (given the possible alternative derivation of the postnominal adjective from a reduced relative clause). With the same classes of adjectives, the postnominal position retains the interpretations found prenominally also in French (see Chapter 2, notes 2 and 6, and Aljović 2000,102), in Spanish (see Bolinger 1972; Luján 1980, chapter 3; Contreras 1981,151; Demonte 1999a,208), in Catalan (see Picallo 2002,1655ff), in Romanian (see Cornilescu 2003b,5;2006,60), and in Portuguese (see Gonzaga 2004, section 2.1.3).

Finally, I should note that the NP (or a larger phrase containing it) may fail to raise above colour and shape adjectives in Italian only in non colloquial styles of the language, giving to such cases as (10)a and (11)a their characteristic ‘poetic’ flavor.

<sup>4</sup> For example, as Brito (1993,49) points out, colour adjectives can precede the N in French (under the same conditions noted for Italian - cf. Blinkenberg 1969,113ff), but not in Portuguese. For further (limited) differences, see the last part of this section.

<sup>5</sup> And presumably the lower classificatory ones. This means that the NP fails to raise over direct modification adjectives except for nationality (and classificatory) ones, *as well as* over all indirect modification adjectives (in reduced relative

---

clauses), which remain prenominal. Related to this, Walloon shows another difference. It allows for the occurrence prenominally of participial reduced relative clauses, which was seen not to be ordinarily possible in the Romance languages considered so far. See (i):

- (i) a dè s r'tchâfés cromptîres      (Bernstein 1991,106)      (cf. French: *des pommes de terre réchauffées*)  
    some reheated potatoes
- b du l'corante êwe      (Bouchard 2002,194)      (cf. French: *de l'eau courante*)  
    of the running water
- c lès cuts pans      (Bouchard 2002,194)      (cf. French: *les pains (bien) cuits*)  
    the baked loaves

<sup>6</sup> Similarly, I would interpret the 'direct' (or 'English') order of (ii) in Hebrew, which Siloni (2001,fn.15) finds possible alongside the unmarked mirror-image order of (i) given by Shlonsky (2000,2005), to involve a relative clause source for the second AP (on the mirror-image order in Hebrew of what she calls 'light' adjectives vs. the free order of what she calls 'heavy' adjectives, arguably derived from relative clauses, see Pereltsvaig 2006a,280; 2006b):

- (i) para švecarit xuma  
    cow swiss brown  
    'a brown Swiss cow'
- (ii) ?para xuma švecarit  
    cow brown swiss  
    'a Swiss brown cow'

As in Italian, the expectation is that with non-predicative adjectives only one order – the mirror-image one– should be possible.

<sup>7</sup> Bouchard (1998, section 6.2) and Knittel (2005,198) take such cases as (i), parallel to (14) and (16) in Italian, to indicate that no rigid order is found postnominally in French, but this conclusion is not warranted. It stems from a failure to distinguish the two sources of adjectives:

- (i) a le lignes parallèles colorées  
    the lines parallel colored  
    'the colored parallel lines'
- b les lignes colorées parallèles  
    the lines colored parallel  
    'the parallel colored lines'

The possibility for certain adjectives to access either one of the two sources can also account for the ambiguity of cases like *les présumés professeurs chinois malhonnêtes* noted in Bouchard's (to appear, section 2.2). In addition to the reading represented by (7) of Chapter 1, repeated here as (ii), where all adjectives are direct modification adjectives and the NP raises above the AP *chinois* and pied pipes it when raising around the higher *malhonnêtes*, there is another possible derivation, in which *présumés* and *chinois* are direct modification adjectives and *malhonnêtes* is an indirect modification AP, as shown in (iii):

(ii) les [ présumés [[ professeurs ] chinois ] malhonnêtes ]

(iii)a les [malhonnêtes [ présumés [ chinois [ professeurs ] ]]] → raising of NP

b les [malhonnêtes [ présumés [[professeurs] [chinois [ ]]]] → raising of the NP plus direct modification APs around the indirect modification AP *malhonnêtes*

c les [[ présumés [ professeurs [ chinois t ] ] malhonnêtes t ]

For the more marked reading which has *malhonnêtes* and *chinois* taking scope over *presumes* (*les [[[ présumés professeurs ] chinois ] malhonnêtes ]*) see the discussion in note 11 of Chapter 3, and related text. If N-movement is unavailable and only movement of NP and pied-piping of the *whose*-picture type (Cinque 2005) is allowed in Romance, no undesired readings (and orders) are derived and perhaps less motivation is left for Bouchard's (to appear) skepticism.

Here we also differ from Laenzlinger (2005a,b), who takes the direct ("English") order of (16) and the mirror-image order of (14) to be alternative options derived either by moving the NP from Spec to Spec (without Pied-Piping) or by moving the NP with subsequent Pied-Piping of the node that dominates the Spec's. The reason for not assuming the two orders to be on a par is the obligatory mirror-image order found when both adjectives are direct modification adjectives, as in (17) and (18).

<sup>8</sup> This is for example the position taken in Cinque (1994), and in other works.

<sup>9</sup> These adjectives also appear to be exclusively prenominal in Spanish (Demonte 1999b,48; Ticio 2003,114), in Catalan (McNally and Boleda 2004,181, Ana Bartra and Maria Luisa Hernanz, pc.), in Portuguese (Gonzaga 2004,23), and in French (Bouchard 1998,2002,63; Aljović 2000,103), although *présumé* is for Christopher Laenzlinger (p.c.) only postnominal.

<sup>10</sup> *Perfetto* 'perfect/total' seems to belong to an entire class of exclusively prenominal adjectives that indicate the way in which a certain description fits. See *un completo sconosciuto* 'a complete stranger', *un vera menzogna* 'a true lie', *una semplice/mera/pura coincidenza* 'a simple/mere/pure coincidence', etc., and corresponding adjectives in the other



---

Romance languages. They can be postnominal (with no change in meaning) only if coordinated. See the text around (10)a-b of Chapter 4, section 4.1.2 for Italian, and the text below for French.

<sup>11</sup> The same seems true of English. See (i)a-c and (ii)a-c:

(i)a past presidents/\*presidents past

b future presidents/\*presidents future

c past and future presidents/presidents past and future

(ii)a my old friends / \*my friends(.) old

b my new friends/\*my friends(.) new

c my old and new friends/ my friends, old and new (cf. Taylor 1992,34fn11)

<sup>12</sup> For some reason, neither stress nor the presence of complements or adjuncts (the other ways of becoming “heavy” – Kayne 1975) are sufficient to make such adjectives “heavy”.

<sup>13</sup> Also see the distinct oddness of *Quel problema è falso* ‘that problem is false’ in the sense of ‘that is a false problem’. The Spanish adjective *falso* appears to be similarly ambiguous. See Demonte (2008,82). On the non ambiguity of the corresponding adjective in Mandarin Chinese, see note 7 of the Appendix.

<sup>14</sup> As noted in Cinque (2005,fn.34), (PP) complements of the N in OV languages interestingly appear in DP-initial position, normally before the Demonstrative. This is for example the case in Turkish (Jaklin Kornfilt, p.c.) and Tatar (cf. Laenzlinger 2009, section 4), in Hindi (Anoop Mahajan, p.c.), in Armenian (Sona Haroutyunian, p.c.), and in Malayalam (K.A. Jayaseelan, p.c.). In other words, like in VO languages, they seem to involve attraction to the P, merged higher up (normally above the demonstrative) but without further movement of the remnant.

<sup>15</sup> In Cinque (1994, section 3), it was noted that bare adjectives cannot follow a PP complement ((i)a) unless they are either heavily stressed ((i)b), modified ((i)c), coordinated ((i)d), or followed by a complement or adjunct ((i)e), and Di Sciullo (1980,79f), and Giurgea (to appear, section 2.6) for corresponding facts in French and Romanian, respectively):

(i)a \*I sostenitori di Gianni fedeli

the supporters of G. faithful

b I sostenitori di Gianni fedéli

the supporters of G. faithful (stressed)

c I sostenitori di Gianni più fedeli

the supporters of G. more faithful

d I sostenitori di Gianni fedeli o presunti tali

the supporters of G. faithful or presumed so

---

e I sostenitori di Gianni fedeli al loro leader

the supporters of G. faithful to their leader

These conditions, however, are not required, apparently, for those adjectives that can be postnominal in English, and that can follow *celui* in French. See the last part of this section and sections 6.3 and 6.4 below for further discussion.

<sup>16</sup> From the existence of PP and relative clause extraposition, we know that both Ps and Cs can be merged at different heights (cf. Kayne 1994,2000,2002).

<sup>17</sup> We would thus take Lamarche's (1991,219) example (i)a to necessarily involve an indirect modification adjective, and his (i)b to involve either a direct or an indirect modification one:

(i)a un groupe de femmes important

a group of women important

b un groupe important de femmes

a group important of women

'an important group of women'

Direct modification adjectives like *principale* 'main' can instead only appear to the left of the PP (see Cinque 1994, section 3).

Cases like *des lunettes de soleil rouges* 'red sunglasses', where the adjective need not be "heavy" and can only appear after the PP (*\*des lunettes rouges de soleil* - Lamarche 1991,219) possibly involve a N P N compound.

<sup>18</sup> Brugè (2002,20) observes that in Spanish adjectives precede the postposed demonstrative, which she argues occupies the same position of the demonstrative reinforcer (*el chico <alto> este <\*alto>* '(lit.) the boy <tall> this <tall>'), unless a pause separates the demonstrative from the adjective, which she shows is necessarily predicative (see her note 5).

As Stefania Chèvre pointed out to me (p.c.), French appears to be like Italian (and Spanish).

<sup>19</sup> Leu (2007a,2008) takes the demonstrative to arise via incorporation of an adjectival demonstrative HERE/THERE (distinct from reinforcer *here/there*) into the determiner. This may be at the basis of Afrikaans *hierdie* (*hier*) (from [*die* [*hier* (*hier*)]] and of languages that have (the equivalent of) *the book here*. I will abstract away here from this and other finer-grained decompositions.

<sup>20</sup> (Non-standard) English *these here* (*four*) (*nice*) *books* (cf. Kayne 2006, section 7), and corresponding sentences in other Germanic languages, could be taken to involve only this movement. The Romance pattern is however not absent from Germanic. See Norwegian *denne boka mi her* (lit. this book my here), from Vangsnes (2004, section 7). As also pointed out there (also see the discussion in Leu 2008, chapter 2), (Eastern) Norwegian can display up to three reinforcers, the first of which must carry (adjectival) inflection: *den herre her populære boka mi (her)* (lit. this here here

---

popular book my (here)). This suggests that the structure in (43) may be too simple.

<sup>21</sup> In Spanish, the demonstrative may be missing (or non pronounced), yielding *el libro de aquí*, not possible in Italian (Brugè 2002, note 13). The other option, also unavailable in Italian, of *el libro este de aquí*, perhaps involves merger of the head attracting *aquí* and merger of *de* inside the XP constituent of (43) (*[este aquí]*), yielding: Det [*este de aquí*] *libro*, followed by attraction of [*este de aquí*] above Det, followed by attraction of the remnant *el libro* above it.